

P. Issue
21/19

ଓଡିଶା ସରକାର
ପଞ୍ଚାୟତିରାଜ ଓ ପାନୀୟ ଜଳ ବିଭାଗ
Government of Odisha
PANCHAYATI RAJ AND DRINKING WATER
DEPARTMENT

୨୭/୧୨/୧୯
୨୭-୧-୧୯

ଓଡିଶା ସଚିବାଳୟ
ସଚିବାଳୟ ମାର୍ଗ, ଭୁବନେଶ୍ୱର-୭୫୧୦୦୧
Odisha Secretariat,
SachibalayaMarg, Bhubaneswar-
751 001
Fax-0674-2391413.
E-mail- nrega.odisha@nic.in

No. 17-NREG-11-1074

16/15

PR& DW/
29 JAN 2019

Date: 22/1/19

From
Prem Chandra Chaudhary, IAS
Director, Special Projects.

To
All Collector-cum-DPCs.

Sub: Revised comprehensive guidelines for construction of AWC in convergence with MGNREGS with W&CD and MS Department and CFC/SFC fund.

Ref: This Department letter no. 41, dated 02.01.2019.

Madam/ Sir,

The revised comprehensive guidelines for construction of AWC in convergence of MGNREGS with W&CD and MS Department and CFC/SFC fund was communicated vide this Department letter no. 41, dated 02.01.2019.

1. Now the revised plan and estimate of the building and toilets prepared by the technical cell of PR & DW Department is enclosed for execution of the project.

2. (A) The designs of interior painting of the AWC building received from W&CD and MS Department vide letter no 304 dated 05.01.2019 are enclosed. These pedagogical designs shall be painted in the interior wall, roof ceiling and floor of the AWC building.

(B) Three types of designs for exterior painting of the AWC building namely (i) Chhota Bheem (ii) Patlu and (iii) Moogli painting received from W&CD and MS Department vide letter no 674 dated 10.01.2019 are enclosed. Any one of the above shall be painted in the exterior walls of the building.

The above interior and exterior painting designs are basic designs which will attract and educate the teen aged children. During execution more features in addition to this may be added with approval of Collector-cum-DPC.

I would therefore request you to instruct the field functionaries to scrupulously follow the above instructions during the construction of the AWC buildings.

Yours faithfully

Director, Special Projects

PTO

Copy communicated for information and necessary action to:

1. OSD to Principal Secretary, PR & DW Department for kind information of Principal Secretary, PR & DW Department.
2. PS to Principal Secretary, W & CD and Mission Shakti Department for kind information of Principal Secretary, W & CD and Mission Shakti Department
3. Director Drinking Water, PR& DW Department.
4. Director, Social Welfare, W & CD and Mission Shakti Department
5. Director, Panchayati Raj, PR & DW Department.
6. All State Nodal Officers of PR & DW Department.
7. All PD, DRDAs/ All Sub-Collectors.
8. All District Panchayat Officers
9. All District Social Welfare Officers
10. All BDOs/ all CDPOs.

Yours faithfully

Director, Special Projects
PTO

P-17
02/01/19

By fax/e-Mail

ଓଡିଶା ସଚିବାଳୟ

ଓଡିଶା ସରକାର
ପଞ୍ଚାୟତିରାଜ ଓ ପାନୀୟ ଜଳ ବିଭାଗ

ସଚିବାଳୟ ମାର୍ଗ, ଭୁବନେଶ୍ୱର-୭୫୧୦୦୧



Government of Odisha
PANCHAYATI RAJ AND DRINKING WATER
DEPARTMENT

Odisha Secretariat, Sachibalaya Marg,
Bhubaneswar-751 001
Fax-0674-2391413
E-mail- nrega.odisha@nic.in

No. 17-NREG-11-1074- 41

/PR&DW Date: 02/01/2019

**REVISED COMPREHENSIVE GUIDELINES ON CONSTRUCTION OF AWC IN
CONVERGENCE OF MGNREGS WITH W & CD AND MISSION SHAKTI
DEPARTMENT AND CFC / SFC FUND**

1. OBJECTIVE:

The construction of Anganwadi Centre is a meaningful thrust for creating a durable community asset for implementation of ICDS package services for the purpose of assimilating, the children from 3-6 years in the pre-school education to create an enabling environment for the physical, psychological, intellectual, and moral development and above all to facilitate their transition from pre-school education to formal school education.

2. CONVERGENCE OF AWC BUILDING:

The construction of AWC will be taken up with an estimated cost of Rs. 7.00 lakh in convergence of MGNREGS funds with W & CD and Mission Shakti Department funds.

	<u>MGNREGS</u>	<u>W & CD and MS</u>	<u>Total</u>
Source of fund :	Rs.5.00 lakh	Rs. 2.00 lakh	Rs. 7.00 lakh

3. EXECUTION OF PROJECT (COMPONENT):

a) **Building:**

- A revised model plan and estimate has been prepared with provision of separate sitting room for children/ women (Classroom), **separate Mamata room**, kitchen, store room, ramp for barrier free movement, electrical wiring etc.

CONSTRUCTION OF TOILET IN NEW AWC BUILDING:

- Separate toilets both for male and female and sanitary & PH fittings are to be constructed in the main building out of MGNREGS. Separate case

record should be opened and maintained for construction of toilet. The estimated cost of the toilet is 1.20 lakhs. The estimate will be approved by the concerned BDO as institutional toilet category under MGNREGS. This will be over and above the MGNREGS share of Rs 5.00 lakhs.

- The revised plan & estimate of AWC is enclosed at **Annexure-I**. The model plan & estimate issued vide this Department Letter No. 6646, dtd. 20.04.2016 is superseded with this revised plan & estimate.

Building Components	Size	Area
Class room	22 feet X 12 feet	264 Sq.ft
Mamata room	7 feet X 6 feet	42 Sq.ft
Store	6 feet X 4.5 feet	26 Sq.ft
Kitchen	7 feet X 6 feet	42 Sq.ft
Verandah	7.33 feet X 6 feet	44 Sq.ft
Ramp	8 feet X 4 feet	32 Sq.ft
Toilet		
Toilet (Male)	6 feet X 4.25 feet	25.5 Sq.ft
Toilet (Female)	5.58 feet X 4.25 feet	23.72 Sq.ft
Over all built up area	(28.75 feet X 20.5 feet) + Ramp	621.38 Sq.ft

- The cost effective process of building construction developed by Central Building Research Institute (CBRI), Roorkee in respect of Rural Housing may be adopted in construction of AWC wherever feasible.
- b) **Colouring & Painting**: A prototype colour pattern, standard painting across walls (outside & inside), inner top of the roof with cartoon character, educative pictorial diagrams etc. has been prepared and enclosed at **Annexure-II** for ready reference.
- c) **Other items of works to be taken up under MGNREGS, W & CD and MS Department and CFC / SFC fund during process of construction of AWC:-**
- i. **MGNREGS fund**:
- **Child friendly green fencing**: The child friendly green fencing around AWC should be taken up out of MGNREGS. The expenditure on green fencing can be incurred over and above the stipulation of Rs. 5.0 lakhs meant for construction of AWC under MGNREGS. Poisonous plants having sharp thorns (Saptapheni) and plants causing irritation and itching shall not be used for green fencing.

AV

- Plantation in the surplus land around the building like Papaya, Coconut, Mango, Drumstick, Banana, Guava, Curry leaf and Lemon to be made out of MGNREGS.
- Separate case record should be opened for green fencing and plantation under MGNREGS.
- Approach road up to the AWC main building shall be constructed by paver blocks.
- Recharge soak pit as per the estimate may also be constructed out of MGNREGS fund for recharging the ground water from the waste water of kitchen of the AWC. This will be over and above the MGNREGS amount of Rs 5.00 lakhs.

ii. **W & CD and Mission Shakti fund:**

Electric Connection to the AWC building:

- The internal electrification and electrical installation including the cost of service connection for **old AWC buildings** will be made out of the funds available with panchayats under CFC/SFC Grant. Accordingly, these provisions may be included in the GP level plans of CFC/SFC Grants and suitable steps be taken for supply of electricity to the old AWC Buildings.
- In case of **new AWC buildings**, the internal electrification & electrical installation including the cost of service connection, wire, meter etc are already included in the estimate and to be met out of the fund allotted by the Department towards construction of AWC buildings.
- Payment of monthly electricity bill shall be budgeted by the Department of W & CD and MS.
- In case energy source is not available, CDPO may explore other option like Solar Light promoted by OREDA and the cost may be borne out of provision from Department of W & CD and MS.
- In case the AWC building is situated at a distance place from electric connection area, the Collector of the Districts are to provide electric supply up to the AWC out of any of the ongoing Rural Electrification schemes continuing in the District.

AV

iii. **CFC/SFC fund:**

- **Construction of Kitchen:** Construction of kitchen / completion of incomplete kitchens may be made out of CFC/SFC funds. Besides, funds allotted by Department of W & CD and MS in this connection may also be utilized for the purpose.

CONSTRUCTION OF TOILETS IN OLD AWC BUILDINGS:

- Construction of toilets in case of old incomplete buildings may be made out of CFC / SFC.
- Construction of toilets in case of old completed buildings may be taken out of CFC / SFC.
- **Water supply facilities:** The water supply facilities for each AWC i.e. provision of overhead tank, tap connection to kitchen and toilet, sinking of tube well wherever necessary and installation of pump set for lifting water to overhead tank may be met out of CFC/SFC fund of the concerned Gram Panchayat. Besides, funds allotted by Department of W & CD and MS in this connection may also be utilized for the purpose.
- **Child friendly elements:** The provision like Slide, Swing, Sea-Saw etc. for amusement of children may be constructed / installed by the Panchayat Samiti in the AWC out of Department of W & CD and MS fund.
- **Repair of the Building:** The minor repair and colouring of the old building (wherever required) may be made out of CFC/SFC fund with the concerned GP and funds from Department of W & CD and MS.

4. **PRIORITY IN SELECTION OF AWCs FOR CONSTRUCTION OF BUILDING:**

- i. AWCs / mini AWCs should be taken up in phased manner.
- ii. **Location:**
 1. Inside the Primary/Upper-Primary School Campus in the service area of the AWC / Mini AWC.
 2. If land is not available inside the Primary/Upper-Primary School campus, it can be taken up in un-objectionable Government land in the service area.

AL

3. BDO will file alienation proposal before the Tahsildar for selection of site.

4. The site for the AWC will be selected as per the provisions of the OGLS Act / Rules and extant guidelines of the Department of W & CD and Mission Shakti.

5. SELECTION OF PROJECT:

- The construction of AWC building, AWC toilet, green fencing, plantation, approach road, recharge pit etc. to be taken up under MGNREGS should be included in the shelf of projects as well as in the Labour Budget duly approved in the Gram Sabha.

6. IMPLEMENTING AGENCY:

- The Panchayat Samiti will be the implementing agency for construction of AWC building and other components of the building under MGNREGA in convergence with W & CD and MS Department fund.

7. WAGE MATERIAL RATIO:

- The wage material ratio of **60:40** shall be maintained at District level for MGNREGS expenditure as a whole for a given financial year. Therefore, adequate no. of wage component oriented works has to be taken up to adjust the material component of AWC. The un-skilled wages shall be paid as per the MGNREGS wage rate. Other wages for skilled, semi-skilled and highly skilled labourers may be paid as per the approved rate notified by Labour & ESI Department. The total un-skilled wage component expenditure shall be booked under MGNREGS.

8. OPENING OF CASE RECORD:

For proper convergence of funds, separate case records will be opened at Panchayat Samittee level.

- One for MGNREGS in which the total estimate (Rs. 7 lakh) of AWC building and the part estimate of the building highlighting the portion of MGNREGS fund (Rs. 5 lakh) will be kept.
- Another case record will be opened for fund from Department of W&CD and MS in which the total estimate of AWC building and the part estimate of the building (Rs. 2 lakh) highlighting the portion of fund of Department



of W & CD and MS will be kept. Both the case records will be tagged together.

- Separate case record for the toilet as institutional latrine amounting to Rs 1.20 lakhs shall be opened.
- Separate case record with estimate for the green fencing with plantation under MGNREGS shall be opened.
- Separate case record to be made for recharge pit.
- Separate case record shall be opened for construction of approach road by paver blocks.
- All above case records are to be tagged together in the main case record.
- Separate case record to be opened for works under CFC/SFC by the concerned GP and copy of the same to be sent to BDO to keep in the case record.

9. TECHNICAL SANCTION AND FINANCIAL SANCTION:

- The Technical Sanction in hard copy of the estimate will be accorded by the competent Technical Authority for MGNREGS work i.e. the Assistant Executive Engineer of the concerned Block.
- The on-line Financial Sanction (FS) for the building and allied components under MGNREGS portion will be accorded by Collector-cum-DPC. The expenditure booked under Department of W & CD and MS component will not be entered in NREGA Soft.

10. OPENING OF ACCOUNT:

- A separate Account will be maintained by the concerned DRDA and the implementing agency for the amount received from W & CD and MS Department.
- Utilization Certificate will also be sent to W & CD and MS Department separately for the amount utilized out of the funds received from W & CD and MS Department through PR & DW Department.
- Similarly, in case of old buildings taken up in convergence with MGNREGS and funds released to BDOs through DSWO, the UC may be submitted through PR & DW Department with a copy to the DSWO.



11. COMPLETION OF THE AWC BUILDING:

- For completion of all the AWC buildings taken up through convergence from 2013-14 to 2015-16, the balance amount required beyond Rs.5.00 lakhs as per the approved plan may be borne out of MGNREGS i.e. for green fencing, plantation, toilet unit, recharge pit and approach road.
- All AWC buildings shall be completed maximum within a period of **one year** from the date of issue of work order.

12. NON-EXECUTION OF PROJECTS:

- The project with estimated cost of Rs. 5 lakhs which has not been started yet shall be cancelled and taken up as a new project with unit cost of Rs. 7 lakh as per the revised guideline.
- In these cases, the funds already allotted by Department of W & CD and MS may be limited to Rs. 2.00 lakh and the balance cost should be met out of MGNREGS.

13. MONITORING AND SUPERVISION:

- The BDOs and CDPOs shall jointly review the progress of AWC in each fortnight. The review of progress of AWC shall also be done at DRDA level on monthly basis.
- The Collector, PD, DRDA and DSWO in course of their visit to the Blocks will make supervision of progress of AWC buildings.
- All State Nodal Officers in course of their visit to the Nodal Districts should supervise the progress of AWC buildings taken up in the Districts.
- The Sub Collector and Chairman ICDS in course of their visit will make supervision of AWC buildings in their respective Sub-Divisional jurisdiction.

14. MAINTENANCE OF ASSET REGISTER:

- An asset register should be maintained at GP/ Block level by the Implementing Agency for recording of the asset grounded. **All such AWCs and allied activities under MGNREGS should also be geotagged as per GeoMGNREGA guidelines issued from time to time.**



15. HANDING OVER OF THE BUILDING TO CDPO:

- The BDO will hand over the completed AWC building to the concerned CDPO within 7 days of the completion of the AWC building in all respect.

16. OPERATIONALIZATION OF THE CENTRE:

- It shall be the responsibility of the CDPOs to operationalize the AWC within 7 days of taking over the building from BDOs.

For any clarification of the above provisions, necessary clarifications have to be obtained from Government of Odisha in Panchayati Raj & Drinking Water Department and W & CD and MS Department.

These guidelines supersede all previous instructions and is given effect to immediately.

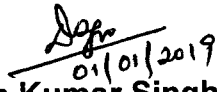

(Anu Garg) 1/1/19
Principal Secretary to Government,
W & CD and Mission Shakti
Department

(Deoranjana Kumar Singh)
Principal Secretary to Government,
Panchayati Raj & Drinking Water
Department

Copy communicated to:

1. OSD to Principal Secretary, PR & DW Department for kind information of Principal Secretary, PR & DW Department.
2. PS to Principal Secretary, W & CD and Mission Shakti Department for kind information of Principal Secretary, W & CD and Mission Shakti Department
3. Director, Drinking Water, PR & DW Department.
4. Director, Special Projects, PR & DW Department.
5. Director, Social Welfare, W & CD and Mission Shakti Department
6. Director, Panchayati Raj, PR & DW Department.
7. All State Nodal Officers of PR & DW Department.
8. All Collectors/ All PD, DRDAs/ All Sub-Collectors
9. All District Panchayat Officers
10. All District Social Welfare Officers
11. All BDOs/ All CDPOs.

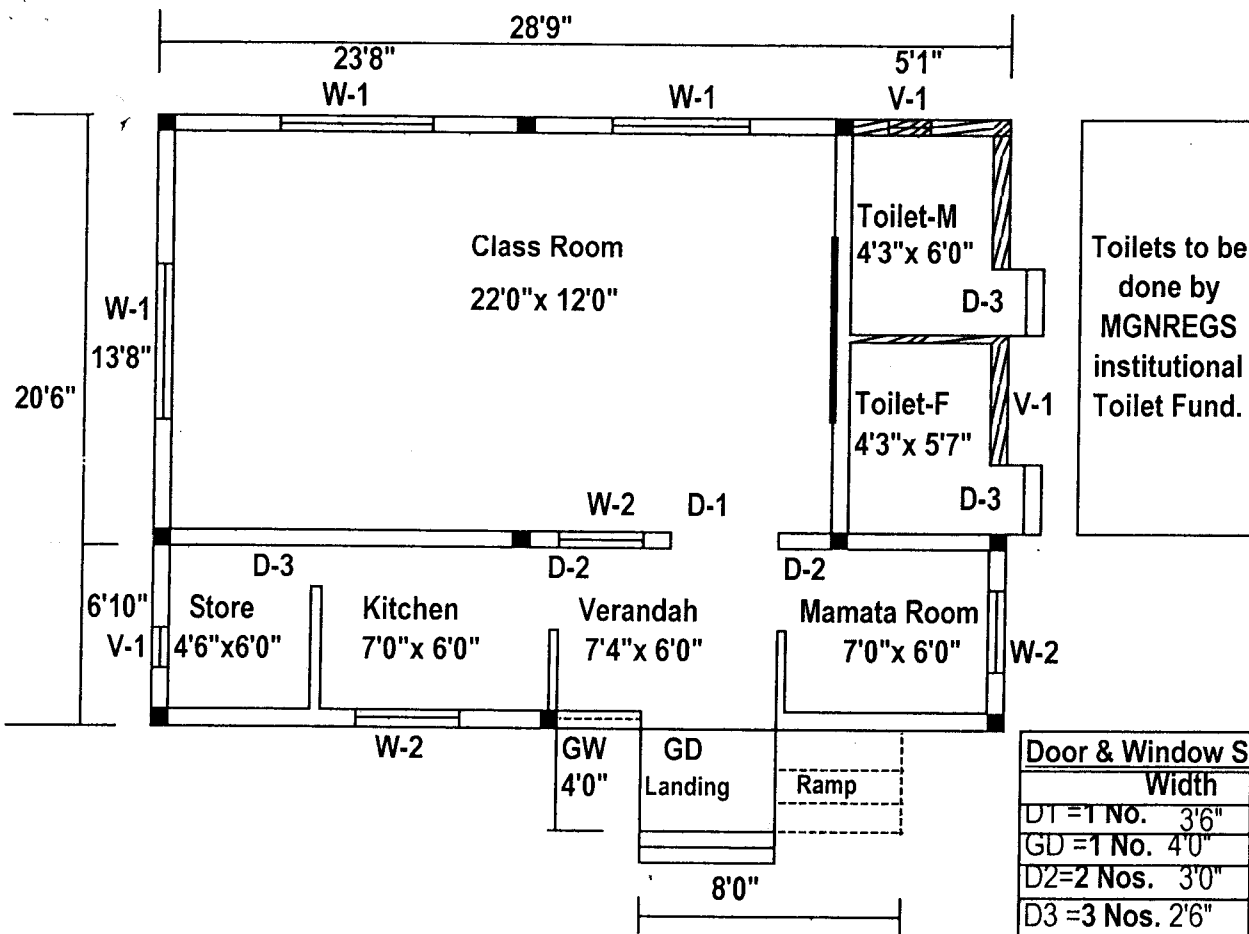
REVISED MODEL PLAN OF AWC BUILDING-II (WITHOUT TOILETS)



Door & Window Specifications		
	Width	Height
D1 = 1 No.	3'6"	7'0"
GD = 1 No.	4'0"	7'0"
D2 = 2 Nos.	3'0"	7'0"
D3 = 3 Nos.	2'6"	7'0"
W-1 = 3 Nos.	4'6"	4'6"
W-2 = 3 Nos.	3'0"	4'6"
GW = 1 No.	3'4"	4'6"
V-1 = 3 Nos.	2'0"	2'0"

GROUND FLOOR PLAN

Builtup area = 621.38 Sft.

(Main Building-(28'9" x 20'6")-(5'1" x 12'10")) = 524.20 Sft.-

Toilet Block-(5'1" x 12'10") = 65.18 Sft., Landing & Ramp (8'0" x 4'0") = 32.00 Sft.)

(Not to Scale)

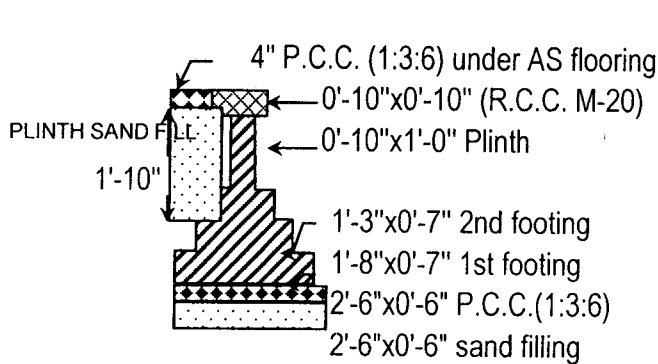

FOUNDATION SECTION OF WALL

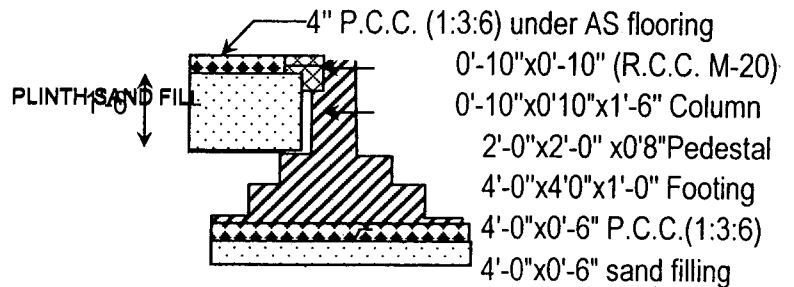

FOUNDATION SECTION OF COLUMN

[Signature]
17/11/18
Junior Engineer
PR & DW Deptt.

[Signature]
17/11/18
Assistant Engineer
PR & DW Deptt.

[Signature]
17/11/18
Superintending Engineer
Panchayati Raj & Drinking Water Deptt.

**DETAILED MODEL REVISE ESTIMATE FOR CONSTRUCTION OF ANGANWADI CENTRE-II
(WITHOUT TOILETS)**

(Estimated Cost = Rs.7,00,000/-)

(Main Building)

Sl.No.	Items	No.	L	B	H	Quantity	Amount in Rs.
--------	-------	-----	---	---	---	----------	---------------

1. Foundation excavation in hard soil including levelling and dressing the bed and sides depositing earth within initial lead and lift etc. complete.

Column	10 x	4' - 00" x	4' - 00" x	4' - 00" =	640.00 cft.
Walls	1 x	125' - 06" x	2' - 06" x	2' - 06" =	784.38 cft.
Steps	1 x	9' - 00" x	1' - 03" x	1' - 00" =	11.25 cft.
	3 x	3' - 00" x	1' - 03" x	1' - 00" =	11.25 cft.
	1 x	4' - 06" x	1' - 05" x	1' - 00" =	6.38 cft.
Deduction for Column	-10 x	1' - 06" x	1' - 06" x	2' - 06" =	-56.25 cft.
				Total =	1397.01 cft.

or say 39.54 cum.@` 94.85 /cum. = Rs. 3,750.00

2. Filling foundation and plinth with sand well watered and rammed including cost, conveyance and royalty of sand etc. complete.

Column	10 x	4' - 00" x	4' - 00" x	0' - 06" =	80.00 cft.
Walls	1 x	125' - 06" x	2' - 06" x	0' - 06" =	156.88 cft.
Plinth(Class Room) -	1 x	22' - 00" x	12' - 00" x	2' - 00" =	528.00 cft.
Plinth(Kitchen Room) -	1 x	7' - 00" x	6' - 00" x	2' - 00" =	84.00 cft.
Plinth(Verandah) -	1 x	7' - 04" x	6' - 00" x	2' - 00" =	88.00 cft.
Plinth(Store Room) -	1 x	4' - 06" x	6' - 00" x	2' - 00" =	54.00 cft.
Plinth(Mamata Room) -	1 x	7' - 00" x	6' - 00" x	2' - 00" =	84.00 cft.
Plinth(Steps) -	1 x	2' - 04" x	2' - 04" x	1' - 06" =	8.16 cft.
	1 x	2' - 04" x	2' - 04" x	0' - 09" =	4.08 cft.
Steps	1 x	9' - 00" x	1' - 03" x	0' - 06" =	5.63 cft.
	3 x	3' - 00" x	1' - 03" x	0' - 06" =	5.63 cft.
	1 x	4' - 06" x	1' - 05" x	0' - 06" =	3.19 cft.
Deduction for Column	-10 x	1' - 06" x	1' - 06" x	0' - 06" =	-11.25 cft.
				Total =	1090.32 cft.

or say 30.86 cum.@` 305.07 /cum. = Rs. 9,413.00

3. Cement concrete 1:3:6 using 4cm. size HBG (hand broken metal) including cost, conveyance and royalty of materials curing etc. complete.

Column	10 x	4' - 00" x	4' - 00" x	0' - 06" =	80.00 cft.
Walls	1 x	125' - 06" x	2' - 06" x	0' - 06" =	156.88 cft.
Plinth(Class Room) -	1 x	22' - 00" x	12' - 00" x	0' - 04" =	87.91 cft.
Plinth(Kitchen Room) -	1 x	7' - 00" x	6' - 00" x	0' - 04" =	13.99 cft.
Plinth(Verandah) -	1 x	7' - 04" x	6' - 00" x	0' - 04" =	14.65 cft.
Plinth(Store Room) -	1 x	4' - 06" x	6' - 00" x	0' - 04" =	8.99 cft.
Plinth(Mamata Room) -	1 x	7' - 00" x	6' - 00" x	0' - 04" =	13.99 cft.
Plinth(Steps) -	1 x	2' - 04" x	2' - 04" x	0' - 04" =	1.81 cft.
	1 x	2' - 04" x	2' - 04" x	0' - 04" =	1.81 cft.
Steps	1 x	9' - 00" x	1' - 03" x	0' - 04" =	3.75 cft.
	3 x	3' - 00" x	1' - 03" x	0' - 04" =	3.75 cft.
	1 x	4' - 06" x	1' - 05" x	0' - 04" =	2.12 cft.
Deduction for Column	-10 x	1' - 06" x	1' - 06" x	0' - 06" =	-11.25 cft.
				Total =	378.40 cft.

or say 10.71 cum.@` 3560.31 /cum. = Rs. 38,127.00

Sl.No.	Items	No.	L	B	H	Quantity	Amount in Rs.
4.	First Class Flyash Brick masonry in C.M. (1:6) in foundation & plinth including cost, conveyance and royalty of materials curing etc. complete.						
	1st Footing	1 x	125' - 06" x	1' - 08" x	0' - 07" =	121.97 cft.	
	2nd Footing	1 x	125' - 06" x	1' - 03" x	0' - 07" =	91.46 cft.	
	Plinth	1 x	125' - 06" x	0' - 10" x	1' - 00" =	104.54 cft.	
	Steps	1 x	8' - 00" x	0' - 10" x	1' - 08" =	11.11 cft.	
		2 x	3' - 02" x	0' - 10" x	1' - 08" =	8.80 cft.	
		1 x	3' - 02" x	0' - 10" x	0' - 10" =	2.20 cft.	
		3 x	3' - 00" x	2' - 00" x	0' - 08" =	12.01 cft.	
		1 x	3' - 00" x	1' - 00" x	0' - 06" =	1.50 cft.	
					Total =	353.59 cft.	
					or say	10.01 cum. @ 3331.80 /cum. =	Rs. 33,341.00
5.	R.C.C. work M-20 grade using 20mm. and down grade HBG (crusher broken chips) including hoisting, laying, cost, conveyance and royalty of materials curing etc. complete.						
	a) Column Base -	10 x	4' - 00" x	4' - 00" x	1' - 00" =	160.00 cft.	
		10 x	2' - 00" x	2' - 00" x	0' - 08" =	26.68 cft.	
					Total =	186.68 cft.	
					or say	5.283 cum. @ 4352.18 /cum. =	Rs. 22,993.00
	b) Plinth Beam -	1 x	125' - 06" x	0' - 10" x	0' - 10" =	87.08 cft.	
					Total =	87.08 cft.	
					or say	2.464 cum. @ 4645.20 /cum. =	Rs. 11,446.00
	c) Column / Beam-	10 x	0' - 10" x	1' - 00" x	13' - 04" =	111.06 cft.	
		1 x	125' - 06" x	0' - 10" x	0' - 10" =	87.08 cft.	
					Total =	198.14 cft.	
					or say	5.607 cum. @ 8929.56 /cum. =	Rs. 50,068.00
	d) Lintel Bend	1 x	107' - 06" x	0' - 10" x	0' - 06" =	44.77 cft.	
		1 x	18' - 00" x	0' - 05" x	0' - 06" =	3.75 cft.	
					Total =	48.52 cft.	
					or say	1.373 cum. @ 7230.16 /cum. =	Rs. 9,927.00
	e) Roof Slab -	1 x	29' - 09" x	21' - 06" x	0' - 05" =	266.72 cft.	
		-1 x	5' - 01" x	12' - 10" x	0' - 05" =	-27.20 cft.	
	Kitchen Slab	1 x	8' - 06" x	2' - 00" x	0' - 2.5" =	3.54 cft.	
	Chajja -W-1	3 x	5' - 06" x	2' - 00" x	0' - 2.5" =	6.86 cft.	
	Chajja -W-2	2 x	4' - 00" x	2' - 00" x	0' - 2.5" =	3.33 cft.	
	Chajja -Ver.	1 x	8' - 04" x	2' - 00" x	0' - 2.5" =	3.47 cft.	
	V-1	1 x	3' - 00" x	1' - 06" x	0' - 2.5" =	0.94 cft.	
					Total =	257.66 cft.	
					or say	7.292 cum. @ 7549.20 /cum. =	Rs. 55,049.00
6.	Supplying, fitting and placing uncoated HYSD bar reinforcement as per drawing and technical specification including cost, conveyance and all taxes of steel and binding wire etc. complete.						
	Quantity of Item No.5	22.019		@ 1.20 Qntl/Cum		= 26.4228 qntl.	
				or say	26.423 Qntl	5897.47 /cum. =	Rs. 155,828.00
7.	First Class Flyash Brick masonry in C.M. (1:6) in superstructure including cost, conveyance and royalty of materials curing etc. complete.						
	Walls	1	107' - 06" x	0' - 10" x	8' - 09" =	783.54 cft.	
	D-1	1 x	3' - 06" x	0' - 10" x	7' - 00" =	-20.41 cft.	
	GD	1 x	4' - 00" x	0' - 10" x	7' - 00" =	-23.32 cft.	
	W-1	3 x	4' - 06" x	0' - 10" x	4' - 06" =	-50.60 cft.	

Sl.No.	Items	No.	L	B	H	Quantity	Amount in Rs.
7.	W-2	3 x	3' - 00" x	0' - 10" x	4' - 06" =	-33.74 cft.	
	GW	1 x	3' - 04" x	0' - 10" x	4' - 06" =	-12.49 cft.	
	V-1	1 x	2' - 00" x	0' - 10" x	2' - 00" =	-3.33 cft.	
					Total =	639.65 cft.	

or say 18.102 cum.@ 3364.80 /cum. = Rs. 60,910.00

8. First Class Flyash Brick masonry in C.M. (1:4) in superstructure including cost, conveyance and royalty of materials curing etc. complete.

Walls of 5"	1 x	18' - 00" x	0' - 05" x	8' - 09" =	65.68 cft.
Kitchen slab wall	3 x	2' - 00" x	0' - 05" x	2' - 06" =	6.26 cft.
D-2	2 x	3' - 00" x	0' - 05" x	7' - 00" =	-17.51 cft.
D-3	1 x	2' - 06" x	0' - 05" x	7' - 00" =	-7.30 cft.
				Total =	47.13 cft.

or say 1.334 cum.@ 3593.21 /cum. = Rs. 4,793.00

9. 20mm. thick cement plaster in c.m. 1:4 grading plaster including cost conveyance and royalty of materials curing etc. complete.

Slab	1 x	29' - 09" x	21' - 06" =	639.63 sft.
	-1 x	5' - 01" x	12' - 10" =	-65.23 sft.
			Total =	574.40 sft.

or say 53.362 sqm.@ 161.75 /sqm. = Rs. 8,631.00

10. 6mm. thick cement plaster in c.m. (1:4) over R.C.C. with close deep chipping including cost conveyance and royalty of materials curing etc. complete.

Class Room	1 x	22' - 00" x	12' - 00" =	264.00 sft.
Kitchen Room	1 x	7' - 00" x	6' - 00" =	42.00 sft.
Verandah	1 x	7' - 04" x	6' - 00" =	44.00 sft.
Store Room	1 x	4' - 06" x	6' - 00" =	27.00 sft.
Mamata Room	1 x	7' - 00" x	6' - 00" =	42.00 sft.
Kitchen Slab	1 x	8' - 06" x	2' - 00" x	17.00 sft.
Chajja -W-1	3 x	5' - 06" x	2' - 00" x	33.00 sft.
Chajja -W-2	2 x	4' - 00" x	2' - 00" x	16.00 sft.
Chajja -Ver.	1 x	8' - 04" x	2' - 00" x	16.67 sft.
V-1	1 x	3' - 00" x	1' - 06" x	4.50 sft.
Beam side	2 x	12' - 00" x	0' - 10" x	19.99 sft.
			Total =	526.16 sft.

or say 48.880 sqm.@ 90.94 /sqm. = Rs. 4,445.00

11. 16 mm. thick cement plaster in c.m. (1:6) over Brick masonry including cost conveyance and royalty of materials curing etc. complete.

Class Room	2 x	(22' - 00" + 12' - 00") x	10' - 01" =	685.64 sft.
Kitchen Room	2 x	(7' - 00" + 6' - 00") x	10' - 01" =	262.16 sft.
Verandah	2 x	(7' - 04" + 6' - 00") x	10' - 01" =	268.87 sft.
Store Room	2 x	(4' - 06" + 6' - 00") x	10' - 01" =	211.74 sft.
Mamata Room	2 x	(7' - 00" + 6' - 00") x	10' - 01" =	262.16 sft.
D-1	1 x	3' - 06" x	7' - 00" =	-24.50 sft.
GD	1 x	4' - 00" x	7' - 00" =	-28.00 sft.
D-2	2 x	3' - 00" x	7' - 00" =	-42.00 sft.
D-3	1 x	2' - 06" x	7' - 00" =	-17.50 sft.
W-1	3 x	4' - 06" x	4' - 06" =	-60.75 sft.
W-2	3 x	3' - 00" x	4' - 06" =	-40.50 sft.
GW	1 x	3' - 04" x	4' - 06" =	-15.00 sft.
V-1	1 x	2' - 00" x	2' - 00" =	-4.00 sft.

Sl.No.	Items	No.	L	B	H	Quantity	Amount in Rs.
--------	-------	-----	---	---	---	----------	---------------

11. **or say 135.478 sqm.@** Total = 1458.32 sft.
 12. 12 mm. thick cement plaster in c.m. (1:6) over Brick masonry including
 cost conveyance and royalty of materials curing etc. complete.
 Out Side 2 x (28' - 09" + 20' - 06") x 12' - 00" = 1182.00 sft.
 Total = 1182.00 sft.
139.02 /sqm. = Rs. 18,834.00

13. Providing and fixing MS Grill in window & door including cost,
 conveyance, taxes and all labour charges etc. complete.
 D-1 1 x 3' - 06" x 7' - 00" = 24.50 sft.
 GD 1 x 4' - 00" x 7' - 00" = 28.00 sft.
 D-2 2 x 3' - 00" x 7' - 00" = 42.00 sft.
 D-3 1 x 2' - 06" x 7' - 00" = 17.50 sft.
 W-1 3 x 4' - 06" x 4' - 06" = 60.75 sft.
 W-2 3 x 3' - 00" x 4' - 06" = 40.50 sft.
 GW 1 x 3' - 04" x 4' - 06" = 15.00 sft.
 V-1 1 x 2' - 00" x 2' - 00" = 4.00 sft.
 Total = 232.25 sft.
@3.50 kg./sft. = 812.88 kg.@ 59.43 /rm. = Rs. 11,378.00

14. 2.5cm. thick A.S.Flooring with C.C.1:2:4 using 12mm. size HBG crusher
 broken chips including punning, cost, conveyance and royalty of materials curing etc. complete.
 Class Room 1 x 22' - 00" x 12' - 00" = 264.00 sft.
 Kitchen Room 1 x 7' - 00" x 6' - 00" = 42.00 sft.
 Verandah 1 x 7' - 04" x 6' - 00" = 44.00 sft.
 Store Room 1 x 4' - 06" x 6' - 00" = 27.00 sft.
 Mamata Room 1 x 7' - 00" x 6' - 00" = 42.00 sft.
 Total = 419.00 sft.
or say 38.925 sqm.@ 218.75 /sqm. = Rs. 8,515.00

15. 12mm thick Cement plaster in C.M.(1:4) with cement punning.
 Class Room 2 x (22' - 00" + 12' - 00") x 0' - 06" = 34.00 sft.
 Kitchen Room 2 x (7' - 00" + 6' - 00") x 0' - 06" = 13.00 sft.
 Verandah 2 x (7' - 04" + 6' - 00") x 0' - 06" = 13.33 sft.
 Store Room 2 x (4' - 06" + 6' - 00") x 0' - 06" = 10.50 sft.
 Mamata Room 2 x (7' - 00" + 6' - 00") x 0' - 06" = 13.00 sft.
 Total = 83.83 sft.
or say 7.788 sqm.@ 125.43 /sqm. = Rs. 977.00

16. Water bound cement priming one coat with cost of all labour & materials, etc.
 For Quantity same as Item No. 10+11+12-15-17
 = 3082.65 sft.
 Total = 3082.65 sft.
43.39 /sqm. = Rs. 12,425.00

17. Finishing inside walls with two coats of distemper of approved shade
 on new work to give an even shade including cost of paint etc. complete.
 For Quantity same as Item No.10+11-15-17
 = 1900.65 sft.
 Total = 1900.65 sft.
47.15 /sqm. = Rs. 8,325.00

18. Finishing outside walls with two coats of weather coat paint of approved shade
 on new work to give an even shade including cost of paint etc. complete.
 For Quantity same as Item No.12
 = 1182.00 sft.
 Total = 1182.00 sft.

Sl.No.	Items	No.	L	B	H	Quantity	Amount in Rs.
--------	-------	-----	---	---	---	----------	---------------

or say 109.808 sqm.@ 54.23 /sqm. = Rs. 5,955.00

18
19. Painting two coats with synthetic enamel paint over a coat of primer of approved quality including cost, conveyance, taxes of all materials, labour, T & P scaffolding, etc.

J-1	2 x	3' - 06" x	7' - 00" =	49.00 sft.
GD	2 x	4' - 00" x	7' - 00" =	56.00 sft.
D-2	4 x	3' - 00" x	7' - 00" =	84.00 sft.
D-3	2 x	2' - 06" x	7' - 00" =	35.00 sft.
W-1	6 x	4' - 06" x	4' - 06" =	121.50 sft.
W-2	6 x	3' - 00" x	4' - 06" =	81.00 sft.
GW	2 x	3' - 04" x	4' - 06" =	30.00 sft.
V-1	2 x	2' - 00" x	2' - 00" =	8.00 sft.
				464.50 sft.

or say 43.152 sqm.@ 137.27 /sqm. = Rs. 5,924.00

Sub Total = Rs. 589,363.00

20. Provision for electrical installation, etc. @ 10 % -

Rs. 58,936.00

21. Provision for Investigation, Quality control & Structural design @ 1.5 % -

Rs. 8,840.00

22. Provision for Green fencing, Creation of Prototypes & Painting, Transparency Board and other unforeseen items to be paid as per actual, etc. -

LS = Rs. 42,861.00

Total = Rs. 700,000.00

Wage : Material = 8 : 92

(Rupees Seven Lakh) only.

N.B.:-

- i)- This is a model estimate. The estimate may be varied according to site condition & as per the requirement.
- ii)- Suitable locally available materials may be substituted if the materials adopted in the model estimate are not available.
- iii)- Rates adopted are tentative. Hence, during execution actual cost may be calculated basing on SoR.

17.11.18
Junior Engineer
PR & DW Deptt.

17/11/18
Assistant Engineer
PR & DW Deptt.

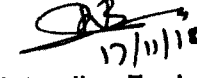
17/11/18
Superintending Engineer
Panchayati Raj & Drinking Water